

# T10-641 "Dual" Extended Side/Bulkhead Mount

Mount Weight 4.00 lb.  
(1.8 kg)

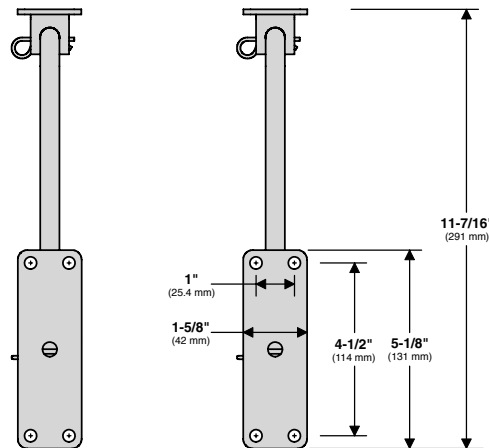

**MAGMA PRODUCTS, INC.**  
3940 PIXIE AVE. • LAKEWOOD, CA 90712  
TEL (562) 627-0500 • FAX (562) 627-0550  
[www.MagmaProducts.com](http://www.MagmaProducts.com)  
email: [Mail@MagmaProducts.com](mailto:Mail@MagmaProducts.com)

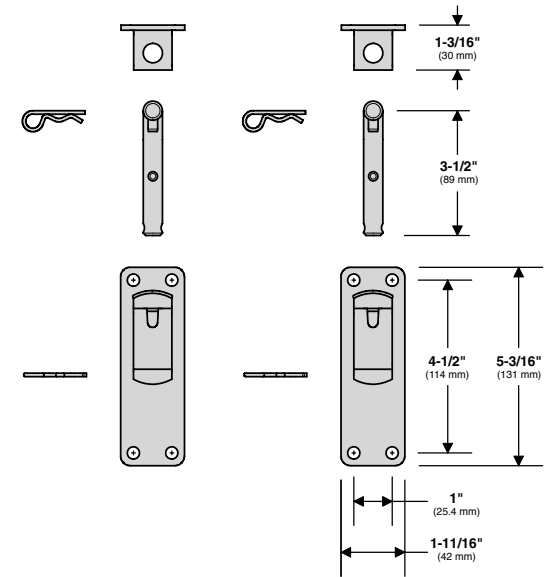
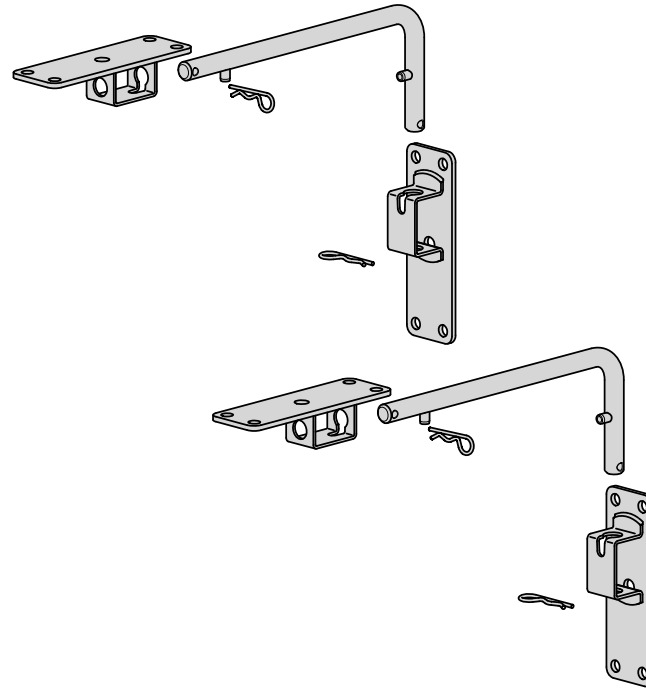

**TOP VIEW**

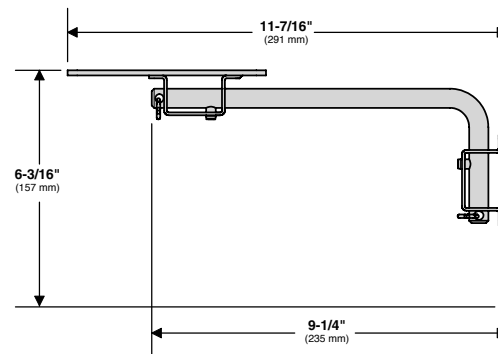

**SIDE VIEW**

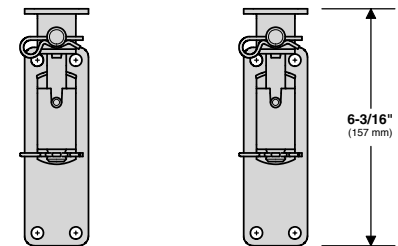

**FRONT VIEW**