

A10-005/A10-006 A10-025/A10-025NZ

Stainless Steel Gas Barbeque



- F** **MANUEL D'UTILISATION**
Barbecue à gaz en acier inoxydable
- D** **BENUTZERHANDBUCH**
Gas Barbecue-Grill aus rostfreiem Stahl
- I** **MANUALE DEL PROPRIETARIO**
Barbecue a gas in acciaio inossidabile
- E** **MANUAL DEL COMPRADOR**
Asador de gas de acero inoxidable



60-006 6/2002



IMPORTANT

Read instructions before operating. Save manual for future reference.

- F** **IMPORTANT**
Lire toutes les instructions avant utilisation. Conserver ce manuel pour toutes consultations ultérieures.
- D** **WICHTIG**
Vor Gebrauch bitte Anleitung lesen. Handbuch für zukünftige Hinweise aufbewahren.
- I** **IMPORTANTE**
Leggere le istruzioni prima dell'uso. Tenere il manuale per referenza futura.
- E** **IMPORTANTE**
Leer las instrucciones antes de usar. Guarde el manual para futuras consultas.



U.S. PATENTS
4,788,962
5,330,154

DES. 292,163

Assembly Instructions

Note: Read complete instructions before operating.

F Instructions De Montage

Note: Lire complètement les instructions avant le montage.

D Anleitung Für Den Zusammenbau

Wichtig: Vor Gebrauch bitte vollständige Anleitung durchlesen.

I Istruzioni Per Il Montaggio

Nota: Leggere interamente le istruzioni prima dell'uso.

E Instrucciones De Montaje

Nota: Leer todas las instrucciones antes de usar.

Tools required
Outils nécessaires
Notwendige Werkzeuge
Strumenti necessari
Herramientas requeridas

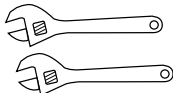

Contents
Contenu
Inhalt
Indice
Contenidos

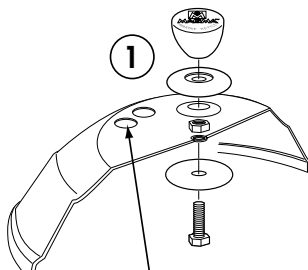

DANGER:
Never Cover Ventilation holes.
DANGER:
Ne jamais couvrir les trous de ventilation.
VORSICHT:
Zugluftöffnungen nie abdecken.
PERICOLO:
Non coprire mai i fori.
PELIGRO:
Nunca cubra los agujeros de ventilación.

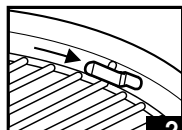
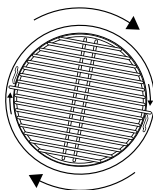
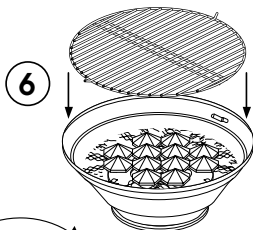
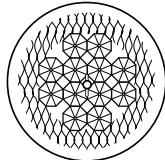
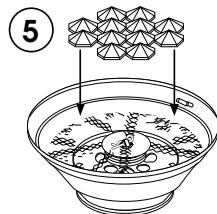
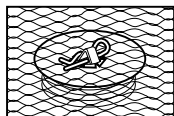
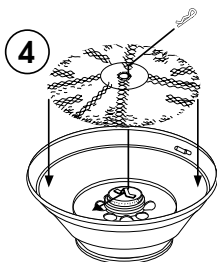
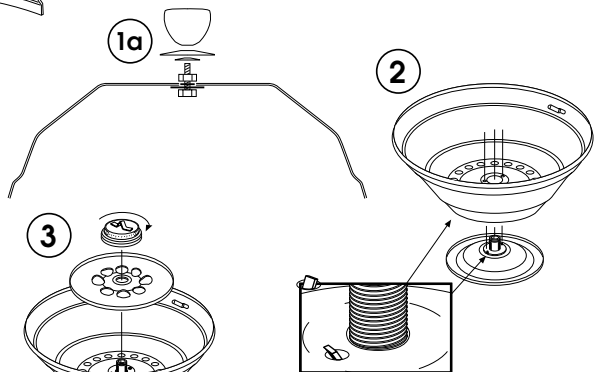

Close-up of Knob & Finger Guard Assembly

Note: Read complete instructions before operating.

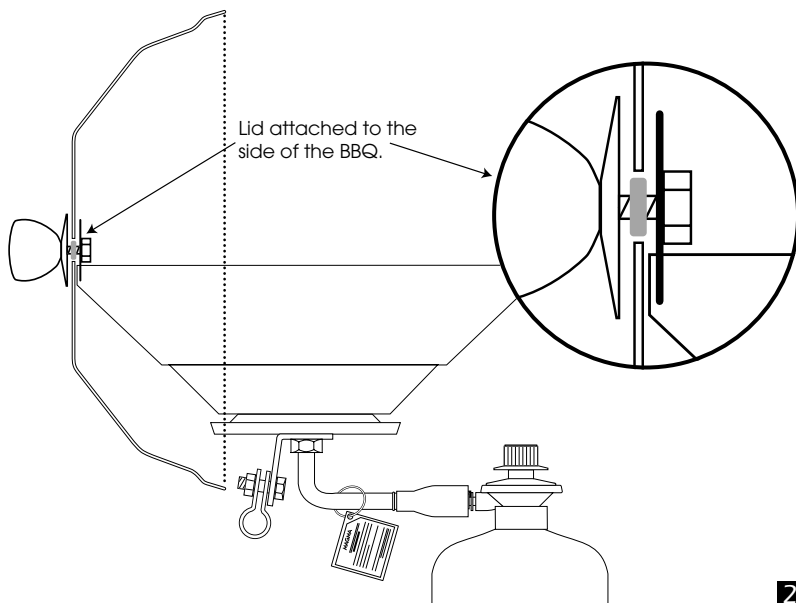
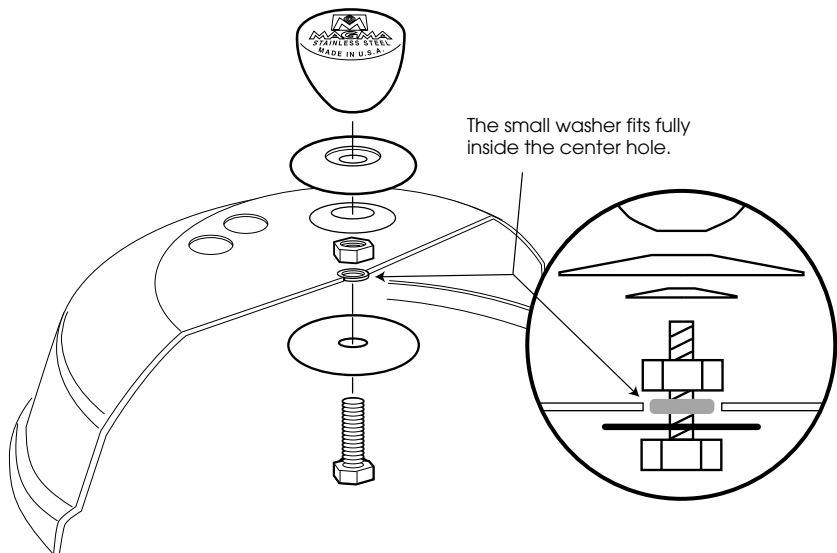

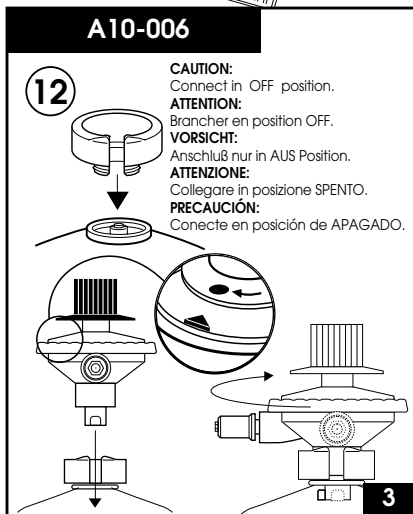
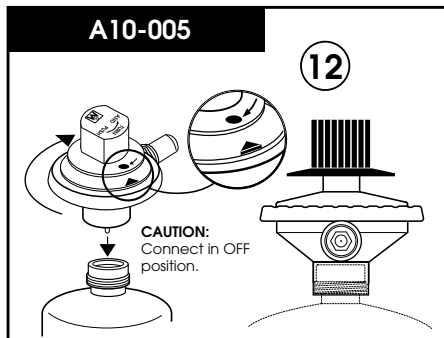
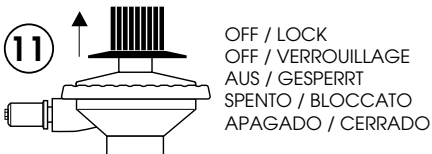
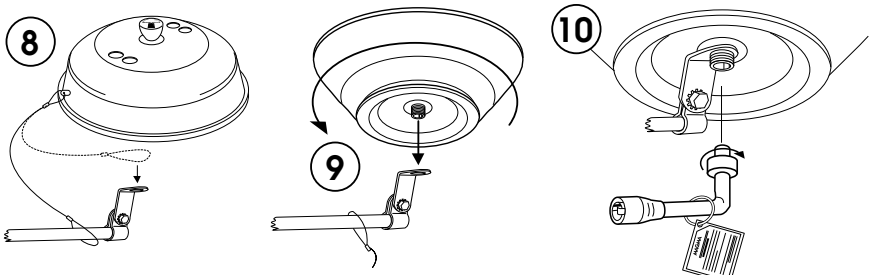
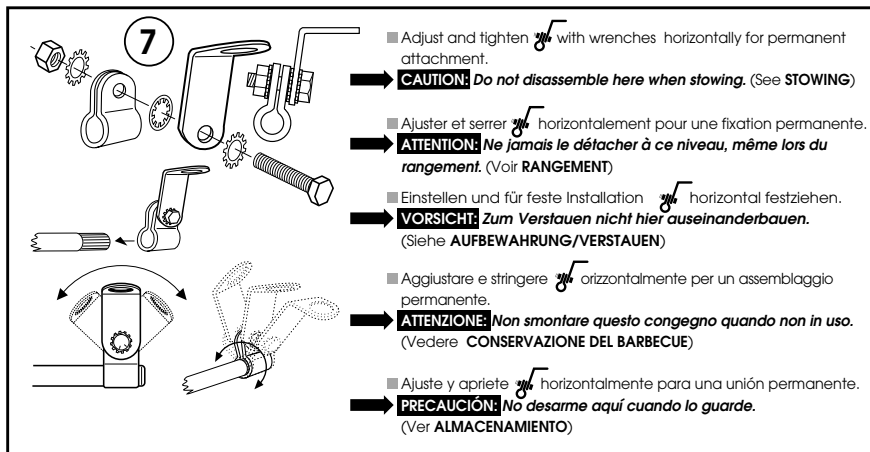

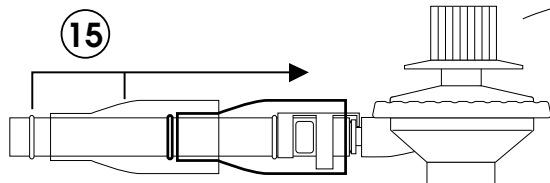
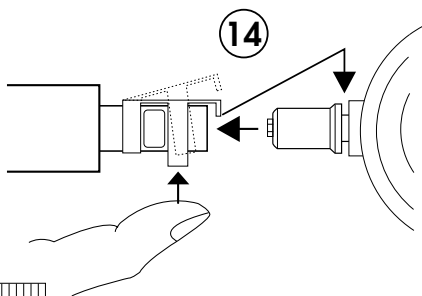
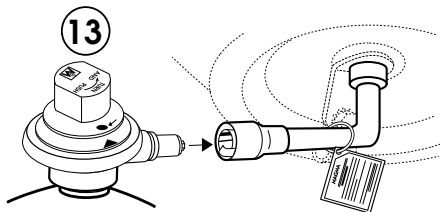

16 Wind block
Coupe-vent
Windschutz
Anti vento
Protección contra el viento

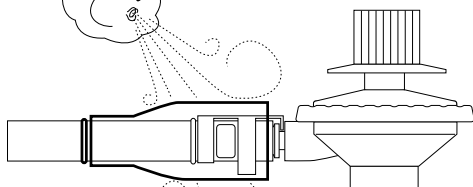

17 Wind block
Coupe-vent
Windschutz
Anti vento
Protección contra el viento

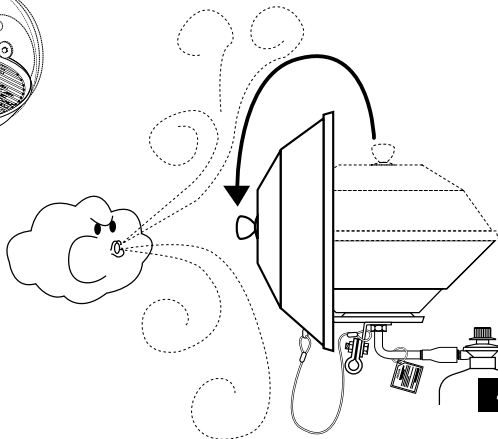
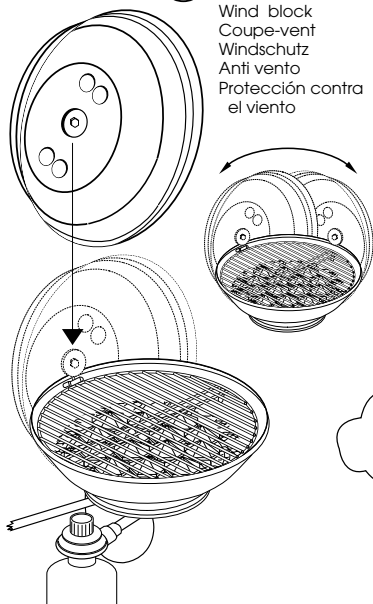

WARNING: Install cartridges in well ventilated area and away from open flame, heat source or sparks. Keep away from other people or flammable materials. See that appliance sealing washer is in place and in good condition. Do not use in closed areas. Ignite only with lid off. Never store gas cartridges indoors or below decks on boats. Use CAMPING GAZ® CV-470 butane gas cartridges with model A10-006 Gas BBQ's. Gas output 10,720 BTU (3161 W).

● SAFETY

- Use outdoors in ventilated area, clearance from combustibles 24 inches (61 cm).
- Never ignite barbeque with lid on.
- When operating barbeque, never leave unattended.
- Use glove or hot pad when handling hot barbeque.
- Always keep a fresh water spray bottle handy to reduce heat and flare-ups.
- **CAUTION: Excessive flare-ups will continue if the barbeque is too hot.**
- **To cool barbeque, spray fresh water on flare-ups until cool.**
- Never leave gas cylinder and regulator connected when stowed.
- Store gas cylinders in well ventilated area.
- Use Magma #A10-210 gas cylinder storage locker. Do not store gas cylinders indoors, in direct sunlight, below decks on boats, or in lockers not approved for butane or propane storage.
- Do not store gas cylinders in temperatures over 120° Fahrenheit (49°Celsius).
- **CAUTION: Check for gas leaks each time cylinder is changed.**
- **NEVER CHECK FOR GAS LEAKS WITH A FLAME!**

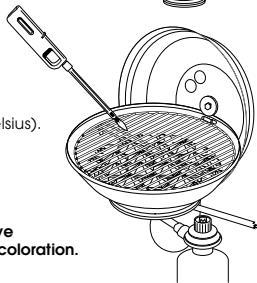

● OPERATING

- **WARNING: DO NOT OVERHEAT BARBEQUE.** Stainless steel loses anti-corrosive characteristics when subjected to extreme heat causing damage and discoloration.
- Hang lid on side of barbeque to block wind. See (17)
- When igniting barbeque, use a long nozzle butane lighter.
- To ignite barbeque, first ignite lighter or match flame , put flame to outer edge of Radiant Screen and Briquets, then turn valve to high "large Δ ".
- To barbeque, cook with lid on.
- **CAUTION: A common mistake is to use too high of a heat setting.** Barbeque will continue to become hotter as you cook. Use moderate heat and be patient. To cool, spray fresh water through cooking grill and reduce flame.

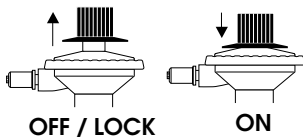

● STOWING

- After barbeque is cool, follow steps (8) through (17) in reverse order.
- **CAUTION: Remove barbeque from mount when stowing.** Do not loosen or detach " σ " to stow. See (7).
- Stow control valve in dry atmosphere.
- **Stow cylinders as per SAFETY instructions above.**

● MAINTENANCE

- Clean barbeque regularly for best performance.
- Clean all metal parts with oven cleaner per oven cleaner instructions.
- Clean all other parts with mild detergent and water.
- **CAUTION: Do not use steel wool or abrasive cleaners**
- Lubricate all threaded areas with petroleum jelly prior to reassembly.

● COOKING TIPS

- A common mistake is to hurry cooking times with too high of a heat setting. **The barbeque becomes hotter while cooking, so start with a low or medium heat setting until familiar with barbeque. When barbequing, cook with lid on.**
- To reduce flare-ups, use lean cuts of meat, trim excessive fat, and avoid oil base marinades.
- If flare-ups occur, lower temperature setting, reduce heat with fresh water spray bottle, and move food away from flare-up.
- For larger cuts of meat or delicate items, use aluminum foil between food and grill to deflect direct heat.
- Lubricate cooking grill with olive oil to keep food from sticking.

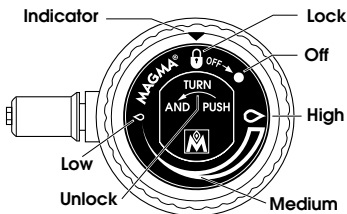

Replacement parts

F Pièces de rechange
D Ersatzteile

I Pezzi di ricambio
E Piezas de repuesto

A10-080 / A10-085

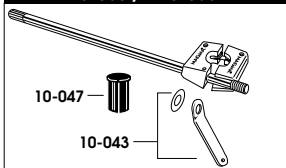

A10-240

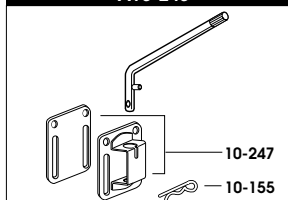

A10-120

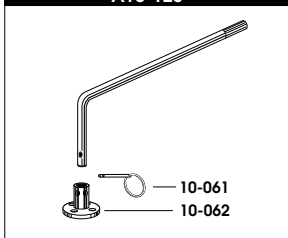

A10-650

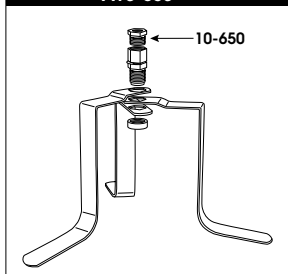

A10-005/A10-006

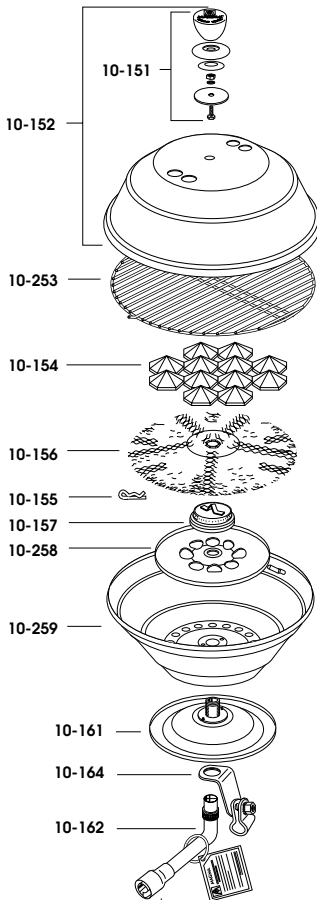

A10-005 BBQ

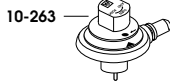

A10-006 BBQ

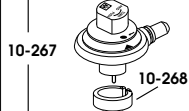

Barbeque Mounts

Round Rail Mount

A10-080 Fits 7/8" or 1" rails (22 mm or 25.5 mm)

A10-085 Fits 1-1/8" or 1-1/4" rails (28.5 mm or 32 mm)

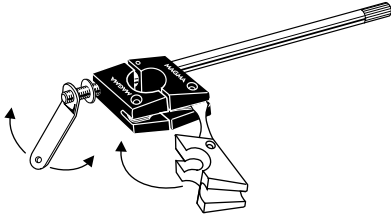

Side (Bulkhead) Mount or Square/Flat Rail Mount

A10-240

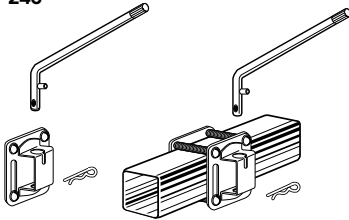

Deck Socket Mount

A10-120

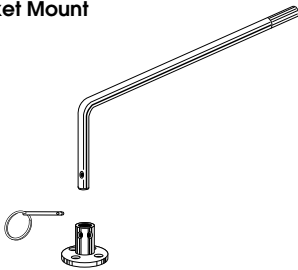

Mounting Extension

A10-140

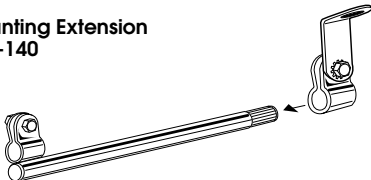

POW'R GRIP™ Fish Rod Holder Mount

A10-175

Fits 1-1/2" to 1-7/8"
inside dia. rod holders
(38 mm to 47.5 mm)

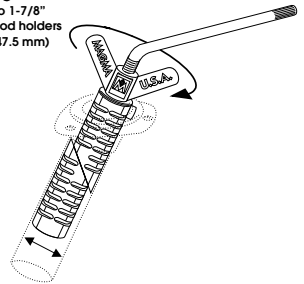

Socket Type Rod Holder Mount

A10-160

Fits Tempres Fish-On®
Rod Holder Sockets

A10-165

Fits Scotty®
Rod Holder Sockets

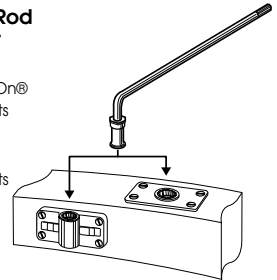

On Shore Stand

A10-650

(for all gas or charcoal
"Marine Kettle"™
barbeques)

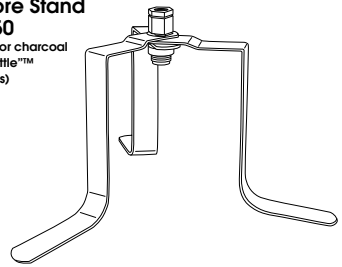

Barbeque Mount Kit for

"Dual-Mount" Tables

T10-515

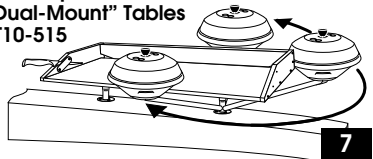

WARRANTY

All products manufactured by Magma are warranted against failures due to materials or workmanship for a period of one year from the original date of purchase (receipt required). Magma must inspect all products claimed to be defective. Magma will not be liable for products damaged due to overheating resulting from neglect or misuse by the user. Magma reserves the right to repair or replace any product. Shipping charges are user's responsibility. Contact Magma first before returning any product.

CALIFORNIA PROPOSITION 65 – WARNING – The burning of gas cooking fuel generates some by-products, which are on the list of substances, which are known by the State of California to cause cancer or reproductive harm. California law requires businesses to warn customers of potential exposure to such substances. To minimize exposure to these substances, always operate this unit according to the use and care manual, ensuring you provide good ventilation when cooking with gas.



MAGMA PRODUCTS, INC.

3940 PIXIE AVENUE • LAKEWOOD, CA 90712 • USA • TEL. (562) 627-0500
e-mail: magmamail@aol.com • Website: www.magmaproducts.com