

A10-004/A10-014

Stainless Steel Charcoal Barbeque



- F** **MANUEL D'UTILISATION**
Barbecue à charbon en acier inoxydable
- D** **BENUTZERHANDBUCH**
Holzkohlen Barbeque-Grill aus rostfreiem Stahl
- I** **MANUALE DEL PROPRIETARIO**
Barbecue a carbone in acciaio inossidabile
- E** **MANUAL DEL COMPRADOR**
Asadores de carbón de acero inoxidable



60-004 9/2002

IMPORTANT

Read instructions before operating.
Save manual for future reference.

- F** **IMPORTANT**
Lire toutes les instructions avant utilisation.
Conserver ce manuel pour toutes consultations ultérieures.

- D** **WICHTIG**
Vor Gebrauch bitte Anleitung lesen.
Handbuch für zukünftige Hinweise aufbewahren.

- I** **IMPORTANTE**
Leggere le istruzioni prima dell'uso.
Tenere il manuale per referenza futura.

- E** **IMPORTANTE**
Leer las instrucciones antes de usar.
Guarde el manual para futuras consultas.

ASSEMBLY INSTRUCTIONS

Note: Read complete instructions before operating.

F INSTRUCTIONS DE MONTAGE

Notare: Lire complètement les instructions avant le montage.

D ANLEITUNG FÜR DEN ZUSAMMENBAU

Wichtig: Vor Gebrauch bitte vollständige Anleitung durchlesen.

I ISTRUZIONI PER IL MONTAGGIO

Notare: Leggere interamente le istruzioni prima dell'uso.

E INSTRUCCIONES DE MONTAJE

Nota: Leer todas las instrucciones antes de usar.

Tools required

Outils nécessaires
Notwendige Werkzeuge
Strumenti necessari
Herramientas requeridas



Contents

Contenu
Inhalt
Indice
Contenidos

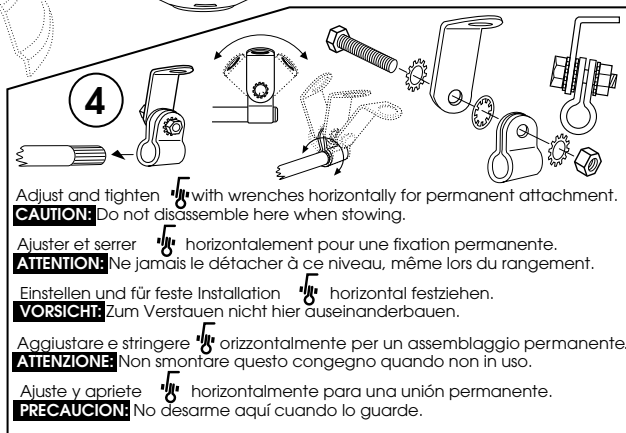
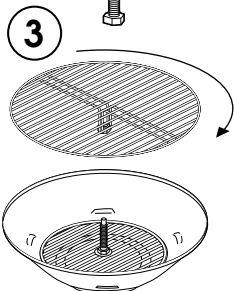
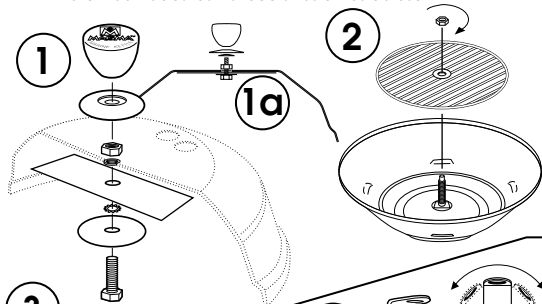
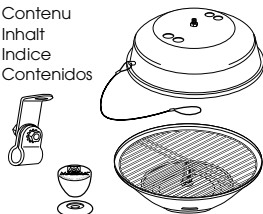

Adjust and tighten  with wrenches horizontally for permanent attachment.
CAUTION: Do not disassemble here when storing.

Ajuster et serrer  horizontalement pour une fixation permanente.
ATTENTION: Ne jamais le détacher à ce niveau, même lors du rangement.

Einstellen und für feste Installation  horizontal festziehen.
VORSICHT: Zum Verstauen nicht hier auseinanderbauen.

Aggiustare e stringere  orizzontalmente per un assemblaggio permanente.
ATTENZIONE: Non smontare questo congegno quando non in uso.

Ajuste y apriete  horizontalmente para una unión permanente.
PRECAUCION: No desarme aquí cuando lo guarde.

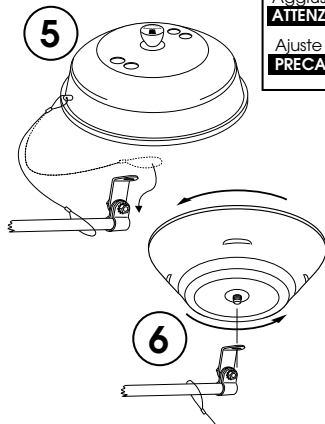

7
Wind block
Coupe-vent
Windschutz
Anti vento
Protección contra el viento

● OPERATING - GETTING READY TO COOK

- Hang barbecue lid to block the wind.
- Remove cooking grill **A**, by unscrewing it from center post.
- Fill Magma "Charcoal Starter" (#A10-150) with briquets, or stack two handfuls away from the center post, then soak the briquets with lighter fluid per can instructions.
- Wait one minute before igniting. Then, preferably, use a long nozzle refillable butane lighter to light the briquets.
- When they are ready, spread the hot coals evenly across the lower grill.
- Replace the upper cooking grill by threading it to the desired height.
- Now you're ready to cook on your Magma barbecue!

NOTE: The Magma "Charcoal Starter" helps extend BBQ life, helps keep threaded rod clean, and makes handling of coals safe and simple.

WARNING: Do not overheat the barbecue. Stainless steel is a strong and long lasting material, but like any metal, extreme heat can cause damage and discoloration.

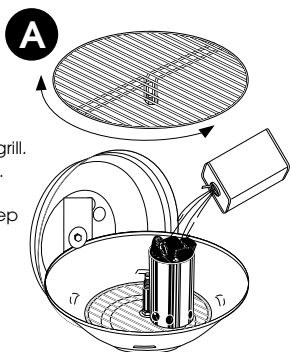

● SAFETY

- Use outdoors in ventilated area, clearance from combustibles 24 inches (61 cm).
- When operating barbecue, never leave unattended.
- Use glove or hot pad when handling hot barbecue.
- Always keep a fresh water spray bottle handy to reduce heat and flare-ups.
- **CAUTION: Excessive flare-ups will continue if the barbecue is too hot. To cool barbecue, spray fresh water on flare-ups until cool.**
- When using lighter fluid read instructions and safety precautions on lighter fluid container.

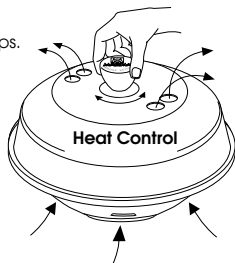

● STOWING

- After barbecue is cool, follow steps **5** **6** & **7** (pg.2) in reverse order and stow.
- **CAUTION: Remove barbecue from mount when stowing. Do not loosen or detach "1/8" to stow. See **4** (pg.2).**
- Remove the cooking grill from the threaded center rod when not in use and for long term storage.

● MAINTENANCE

- Clean barbecue regularly for best performance.
- Clean and lubricate the threaded center rod between uses.
- Clean all metal parts with oven cleaner per oven cleaner instructions.
- **CAUTION: Do not use steel wool or abrasive cleaners.**
- Clean all other parts with mild detergent and water.

● COOKING TIPS

- Always cook with lid on.
- Timing is very important. Make sure food is prepared before lighting the barbecue so cooking is completed while the briquets are still hot.
- **The barbecue becomes hotter while cooking. Frequent checks should be made during cooking until familiar with barbecue.**
- To reduce flare-ups, use lean cuts of meat, trim excessive fat or skin, and avoid oil base marinades.
- If flare-ups occur, reduce heat with fresh water spray bottle, and move food away from flare-up.
- For larger cuts of meat or delicate items, use aluminum foil between food and grill to deflect direct heat.
- Lubricate cooking grill with olive oil to keep food from sticking.

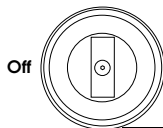
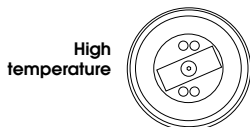

Barbeque Mounts

Round Rail Mount

A10-080 Fits 7/8" or 1" rails (22 mm or 25.5 mm)

A10-085 Fits 1-1/8" or 1-1/4" rails (28.5 mm or 32 mm)

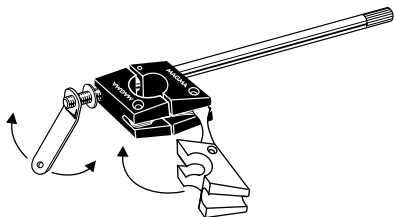

POW'R GRIP™ Fish Rod Holder Mount

A10-175

Fits 1-1/2" to 1-7/8"
inside dia. rod holders
(38 mm to 47.5 mm)

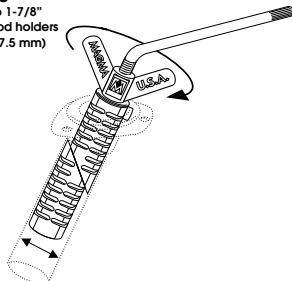

Side (Bulkhead) Mount or Square/Flat Rail Mount

A10-240

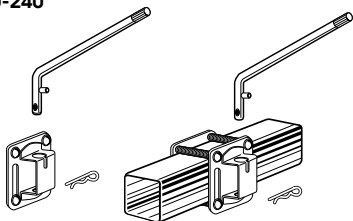

Socket Type Rod Holder Mount

A10-160

Fits Tempress Fish-On®
Rod Holder Sockets

A10-165

Fits Scotty®
Rod Holder Sockets

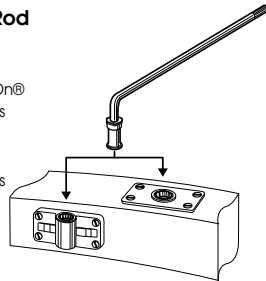

Deck Socket Mount

A10-120

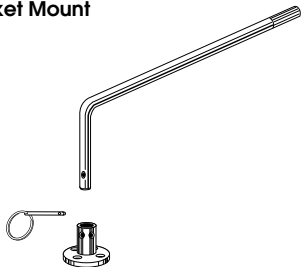

On Shore Stand

A10-650

(for all gas or charcoal
"Marine Kettle"™
barbeques)

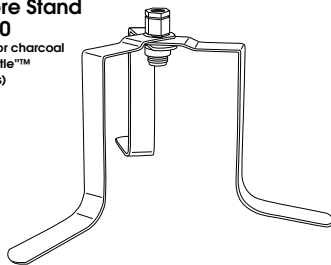

Mounting Extension

A10-140

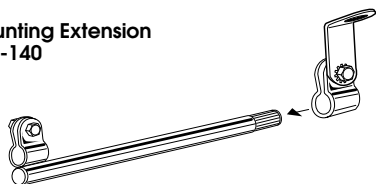

Barbeque Mount Kit for "Dual-Mount" Tables

T10-515

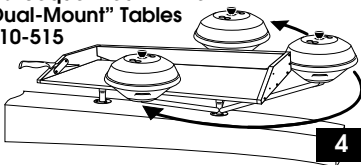

Replacement Parts

F Pièces de rechange
D Ersatzteile

I Pezzi di ricambio
E Piezas de repuesto

A10-004

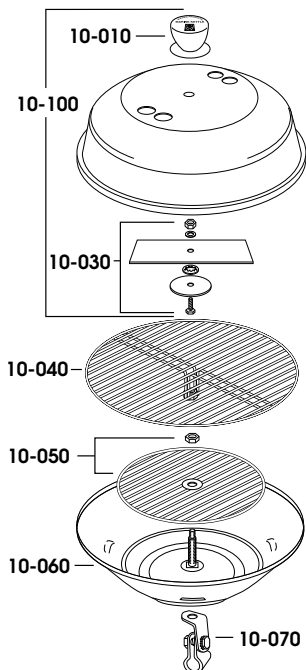

A10-014

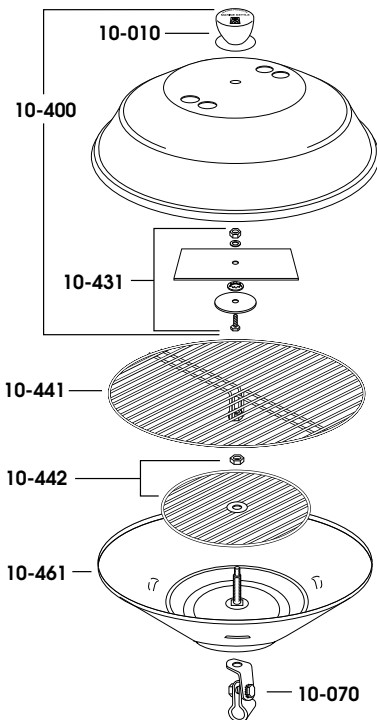

A10-080
A10-085

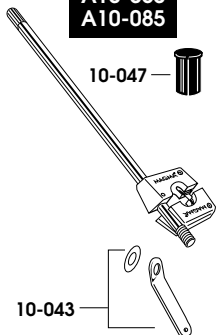

A10-240

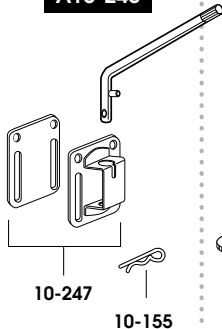

A10-120

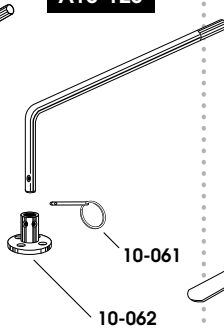

A10-650

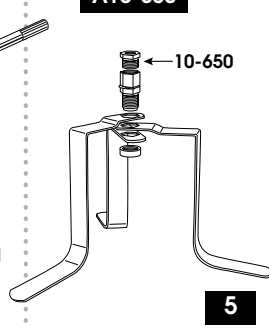

WARRANTY

All products manufactured by Magma are warranted against failures due to materials or workmanship for a period of one year from the original date of purchase (receipt required). Magma must inspect all products claimed to be defective. Magma will not be liable for products damaged due to overheating resulting from neglect or misuse by the user. Magma reserves the right to repair or replace any product. Shipping charges are user's responsibility. Contact Magma first before returning any product.

CALIFORNIA PROPOSITION 65 – WARNING – The burning of gas cooking fuel generates some by-products, which are on the list of substances, which are known by the State of California to cause cancer or reproductive harm. California law requires businesses to warn customers of potential exposure to such substances. To minimize exposure to these substances, always operate this unit according to the use and care manual, ensuring you provide good ventilation when cooking with gas.



MAGMA PRODUCTS, INC.

3940 PIXIE AVENUE • LAKEWOOD, CA 90712 • USA • TEL. (562) 627-0500
e-mail: magmamail@aol.com • Website: www.magmaproducts.com